

# MOBILE BBQ CART

Aluminum Cabinets and Carts For Shop, Trailer & Track



## Introducing The "GRILL" Cart

Front



Cart Dimensions: 67" Long, 42" High, 30" Wide

Back



### Grill Features

- Bull BBQ Angus Grill
- 16 Gauge 304 Stainless Steel Construction
- Illuminated Cooking Area
- Rotisserie
- 4 Cast Stainless Burners-15,000 BTU's each (60,000 BTU's Total)

### Cart Features

- 16 Gauge 304 Stainless Steel Top
- All Aluminum Construction
- 1 Large and 1 Small *MotionLatch™* Drawer For Utensil Storage
- 5 Storage Compartments With Adjustable Shelving
- *MotionLatch™* Drawer Handles
- Slide Out Propane Tank
- Burris Premium Wheels With Racing Slicks
- 4 D-ring Tie Down Points
- Ship to Shore Power With 110 Volt Receptacles
- External Fire Extinguisher
- Weight 425 lbs.
- Heavy Duty Cover Available

End



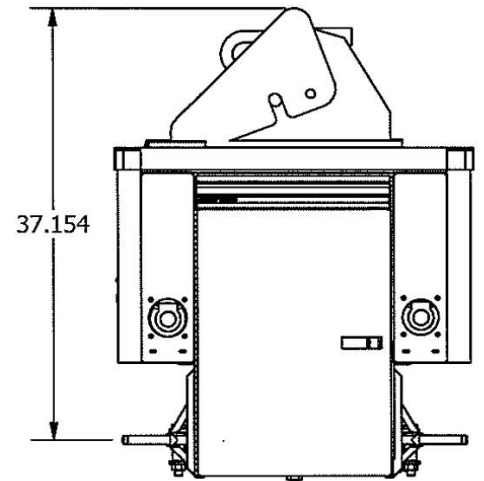
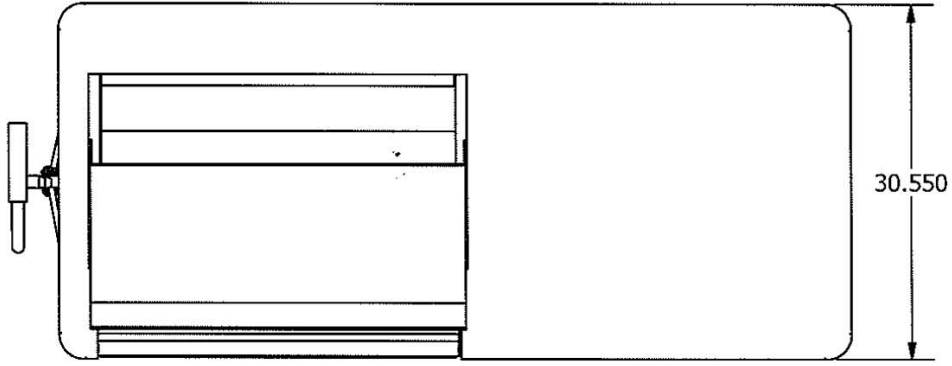

**Proprietary Notice**

*This drawing and the text, design, and concepts herein are the property of CTECH Trailer Cabinets, a division of Greenheck Racing. Any reproduction, distribution, or forwarding of this document to persons or organizations for any reason with out written permission from CTECH is prohibited.*